



# Backyard Hens

## Summary Guide

**Do you live in a single family residential neighborhood on a lot smaller than 30,000 square feet?**

If so, you may keep up to 6 female chickens (hens), as long as they are kept in accordance with the following provisions:

- Complete a permit application - prior to housing your future fowl, you will need to submit an application for a hen permit. The following information must be submitted:
  - Layout of the coop and run in accordance with the guidelines provided.



- Permits are issued for a 1 year period and may be renewed for an additional 2 years.
- Roosters are prohibited. 
- Hens must be kept in a covered coop or an enclosed run area at all times.
- Keep feed and other items associated with the keeping of hens clean and sanitary at all times to prevent the infestation of rats, mice and other rodents.
- Hens are not to be raised for the purpose of slaughtering.

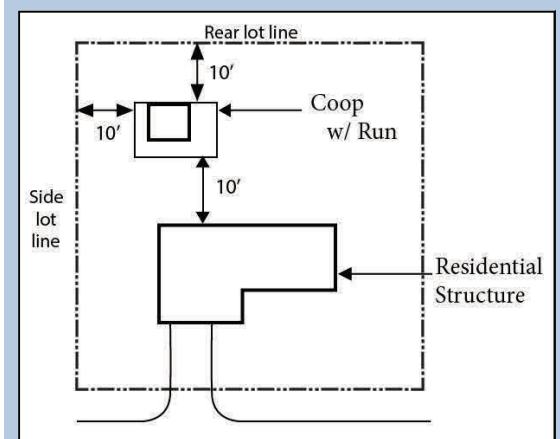

### Coop and run area guidelines:

- ψ Must be at least 30 feet from any residential structure not owned by the permittee and at least 10 feet from any property line.
- ψ Must be located in the rear yard and designed to minimize visual impact.
- ψ Coops must be covered with direct access to an enclosed run area.



## Disclosures

- \* Private restrictions by HOA's or similar organizations on the use of property shall remain enforceable and may prohibit the keeping of chickens.
- \* If these requirements are not fully complied with, the city may revoke any permit granted under this section and/or initiate prosecution for civil infraction violation.



**CITY OF LIBERTY, MISSOURI  
PERMIT TO KEEP BACKYARD HENS**

**Please submit permit application to:**

City of Liberty  
Planning & Zoning Division  
101 E Kansas Street  
Liberty, MO 64068

**Applicant Name:** \_\_\_\_\_

**Property Address:** \_\_\_\_\_

**Phone Number** \_\_\_\_\_ **E-mail Address:** \_\_\_\_\_

Please attach the appropriate required documentation to this application and check the box that you understand and have complied with the terms of this ordinance requirement.

Photograph (premade coop) or copy of plans (homemade coop) for the chicken coop and run.

A site plan of the back yard which clearly outlines property lines, any existing and proposed structures (proposed coop, run, existing house, etc.), any existing and proposed setback distance between the proposed coop and run, any structures and property lines. All coops and runs must be at least ten (10) feet from any property line and at least thirty (30) feet from any neighboring residence.

**I understand the restrictions on the permit and am submitting this application in compliance with Section 30-80.1(7) b as listed on back.**

**Applicant Signature** \_\_\_\_\_ **Date** \_\_\_\_\_

<b>Office Use Only</b>	
Received: _____	Approved/Denied: _____
Expiration Date: _____	Comments: _____

\*This permit must be kept by the owner and presented upon demand by any city official. Permits are non-transferable and may not be sold or assigned. Renewal permits require full re-submittal.

**Section 30-80.1(7) b**

For single-family residential lots smaller than thirty thousand (30,000) square foot in area, or larger lots which cannot satisfy the setbacks outlined in 30-80.1, up to six (6) female chickens (hens) may be kept in accordance with the following provisions:

- i. Prior to keeping or housing hens, a person shall first submit an application for a hen permit to the City of Liberty Planning Division. Said permits may be issued for a one-year period and may be renewed for two (2) years. Permits are non-transferable. Each applicant must submit information or evidence of the following for permits and renewal permits:

All hens must have access to a covered enclosure (or coop) that allows for the housing of the hens. In addition, all coops must have direct access to an enclosed run area. All coops and runs shall be located in the rear yard and be designed in a manner to minimize their visual impact. All coops and runs shall be at least ten (10) feet from any property line and at least thirty (30) feet from any residential structure not owned by the permittee.
- ii. The keeping of roosters and guinea hens, or any fowl other than female chickens, is prohibited.
- iii. At all times, hens shall either be kept in a coop or a run as defined above.
- iv. All feed and other items associated with the keeping of hens shall be kept clean and sanitary at all times and be protected so as to prevent the infestation of rats, mice, or other rodents.
- v. The hens are not raised for the purpose of slaughtering.
- vi. Notwithstanding the issuance of a permit by the city, private restrictions on the use of property shall remain enforceable and may prohibit the keeping of hens as provided herein. A permit issued to a person whose property is subject to private restrictions that prohibit the keeping of hens is void. The interpretation and enforcement of the private restriction is the sole responsibility of the private parties involved.
- vii. If the requirements of this section are not fully complied with, the city may revoke any permit granted under this section and/or initiate prosecution for a civil infraction violation.